



14500 Coy Drive, Grass Lake, Michigan 49240
734-475-2200 E-mail: sales@coylab.com
www.coylab.com

Basic Vinyl Glove Bag Instruction Manual

INDEX

1.0 Description

1.0	Warning	2
1.1	Warranty	2
1.2	Glove Bag Assembly	3
1.3	Glove Bag Components & Operation	7
1.3.1	Ball Valve	8
1.3.2	Pressure Relief Bubbler	8
1.3.3	Plug Strip & Utility Nipples	10

2.0 Care and Maintenance

2.1	Care of PVC	11
2.2	Care of the gloves	13

1.0 Warning

Never purge the glove bag at a higher rate than 15 psi. (with ¼” ID Tubing). Doing so could over pressurize and damage the glove box.

1.1 Warranty

The Glove Bag and all accessories contained in this chamber are warranted against defects in material and workmanship during the first 12 months after original date of shipment.

The factory will, at its option, repair or replace defective materials within the above period at no charge for parts and labor.

All returns or exchanges must first be authorized by Coy Laboratory Products.

Phone: 734-475-2200

Fax: 734-475-1846

Shipping address: 14500 Coy Drive
Grass Lake, MI 49240

The responsibility of Coy Laboratory Products, Inc., is limited to the purchase price of this product, and Coy Laboratory Products, Inc. will not be responsible for any consequential damages.

This warranty does not cover damage in shipment or damage as a result of improper use or maintenance of this product, This warranty does not cover damages caused by excessive line transients on the AC supply line.

1.2 Vinyl Glove Bag Assembly

The Glove Box is shipped collapsed to save on shipping cost. Please use the following instructions and diagrams to assemble the vinyl bag, aluminum support frame, and the pressure relief mechanism. If an optional airlock has been ordered with the vinyl bag, this will have been installed and tested at the factory.

Assembly instructions

MAKE SURE THE CHAMBER IS AT ROOM TEMPERATURE BEFORE YOU BEGIN ASSEMBLY PROCEDURE. PVC (the plastic from which the Chamber is made) is very brittle at low temperatures. Prior to shipment, the Chamber has been assembled and tested for leaks at the factory. Figure # 1 (page 4) can be used as an aid to assemble the Chamber.

1. Locate the Chamber Care Kit supplied with the chamber. Inside the care kit you will find miscellaneous items needed to assemble and maintain the Chamber. They are:

QUANTITY DESCRIPTION

1	ROLL OF YELLOW TAPE (Used to seal equipment, entry port & gloves).
1	PAIR NEOPRENE RUBBER GLOVES
1	PLASTIC CUFF
1	PAIR CANVAS WORK GLOVES (Used to slip over rubber gloves for protection against punctures and cuts.)
1	VINYL REPAIR KIT
1	1/8" ALLEN WRENCH (For assembly)
1	5/32" ALLEN WRENCH (For assembly)

2. Once you have found a suitable place to set the Chamber, insert the side supports (1,3) in their cups (screwed to the Chamber base 5,8). As you will notice in Figure 1, and by inspection, the side supports are not symmetrical. At the bottom of each support, one side is bent at a slight angle (7). This bend allows the Chamber to slant away from the user's face when it is fully assembled. The side that is bent is inserted in the cup closest to the front of the Chamber (5). Side support cups are located on all four corners of the Chamber. **DO NOT TIGHTEN THE SETSCREWS THREADED IN THE CUPS, YOU WILL DO THIS LATER.**
3. Next, insert the two straight aluminum poles (2) into the PVC hangers (the PVC hangers are actually sleeves parallel to the Chamber base and located on the top side of the Chamber). One hanger is in front of the Chamber and the other is in back of the Chamber. **DO NOT FORCE THE POLES THROUGH THE HANGERS.** Rather, insert them with a rotating motion, which will help guide them. Then, with two people, lift one

pole (either in front or back of the Chamber) and insert it in the cups (4) located above the Chamber base. You may have to spread the side supports slightly to insert the aluminum poles. One cup is on the right side support (3) and the other is on the left side support (1). Now, install the other aluminum pole in the same manner as the first.

4. With the 5/32" allen wrench tighten the setscrews located on ALL of the cups. Tightening the setscrews will make the Chamber's frame ridged and self-supporting. The Chamber should now be standing and ready for large equipment installation.

Figure #1 Aluminum Frame Support and Padded Base Set-Up

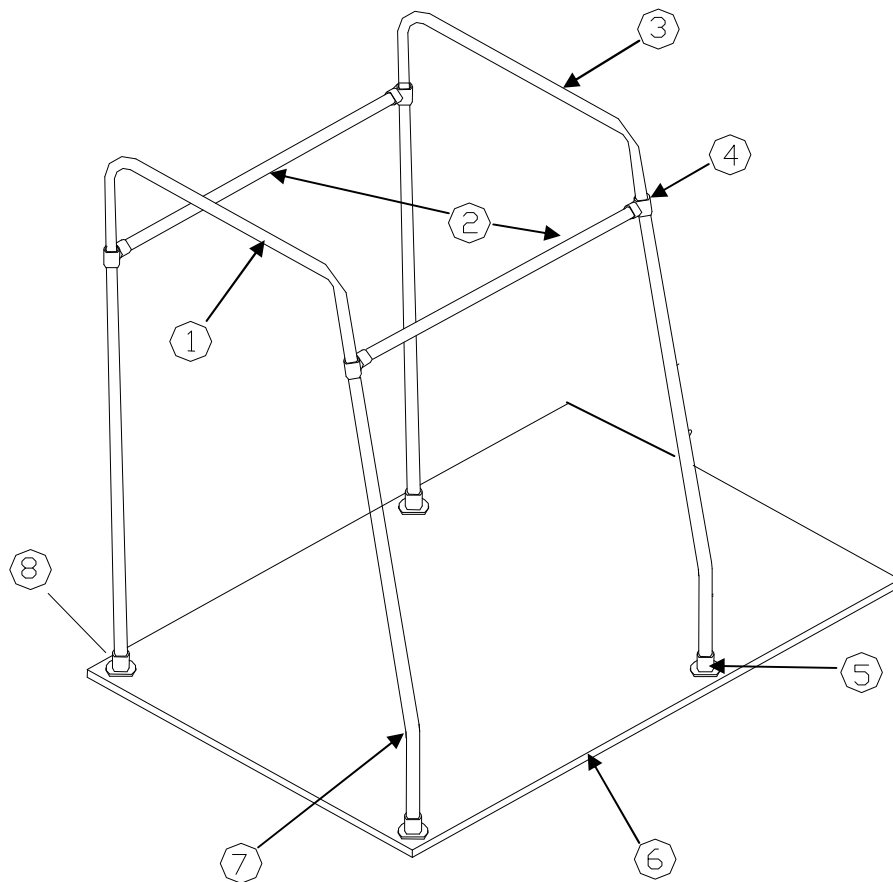

Figure #1 Legend

- | | |
|----------------------------|---------------------------------|
| 1. Left Side Support | 5. Front Side Support Cups |
| 3. Right Side Support | 6. Chamber Base |
| 2. Straight Aluminum Pole | 7. Slight Angle on Side Support |
| 4. Cup, Above Chamber Base | 8. Rear Side Support Cups |

5. Before you install large equipment, you must first insert the 6 receptacle plug strip. Slide the plug strip through the large utility nipple located at the bottom rear left hand side or the side opposite the optional airlock. When the plug strip is completely inside the Chamber, forcefully push the plug strip's stopper into the nipple. Wetting the stopper with water will help you push it into the nipple. The best location for the plug strip is in the back of the Chamber.

NOTE: For UK users this has already been done at the factory due to the size of plug strip and the special installation procedures required.

6. Now you are ready to install large equipment through the large equipment entry port. Large equipment is defined as anything too big to fit in the airlock or side door, such as a Coy Incubator, Fan Boxes, Work Mats, and Shelving Units. Arrange the items to provide maximum work area. Coy recommends placing the work mats in front of the gloves. Arrange your equipment and COY accessories as desired.
7. Once large equipment has been installed, and arranged to your satisfaction, and plugged into the power strip, seal the large equipment entry port with the plastic disc supplied. To do this, orientate the disc so that the serial number (black sticker) of the plastic disc is on the outside of glove bag. Next, push the disc through the large opening and begin the sealing process by grasping the outside of the disc with both hands and pulling it through the hole until about 2" of PVC is resting on the sides of the disc (Figure #2, page 7). With one hand, hold the PVC in place; and with the other used as a lever, stretch the PVC over the disc. After the PVC has been stretched over the disc, seal the junction where the PVC and disc meet with yellow tape (supplied with your Chamber Care Kit). Taping the PVC and disc together is an important procedure and should be done with care so the tape does not wrinkle. Coy recommends 6 revolutions of tape to ensure an adequate airtight seal. The first revolution of tape should be very flat and straddle the PVC and disc. This first revolution of tape actually seals the large equipment port. The remaining revolutions ensure a complete seal by overlapping the first revolution on both sides. When you complete step 7, there should be a band of yellow tape (created by the overlapping tape) about 3" wide.
8. Finally, install the Pressure Relief Mechanism by inserting the Inlet Nipple on the Pressure Relief Mechanism (Figure #5 page 10) into the Utility Nipple located behind the airlock and secure together with the supplied hose clamp. Pour in all of the supplied mineral oil (473 ml or 1 pint.)

Figure #2 Large Equipment Port Installation

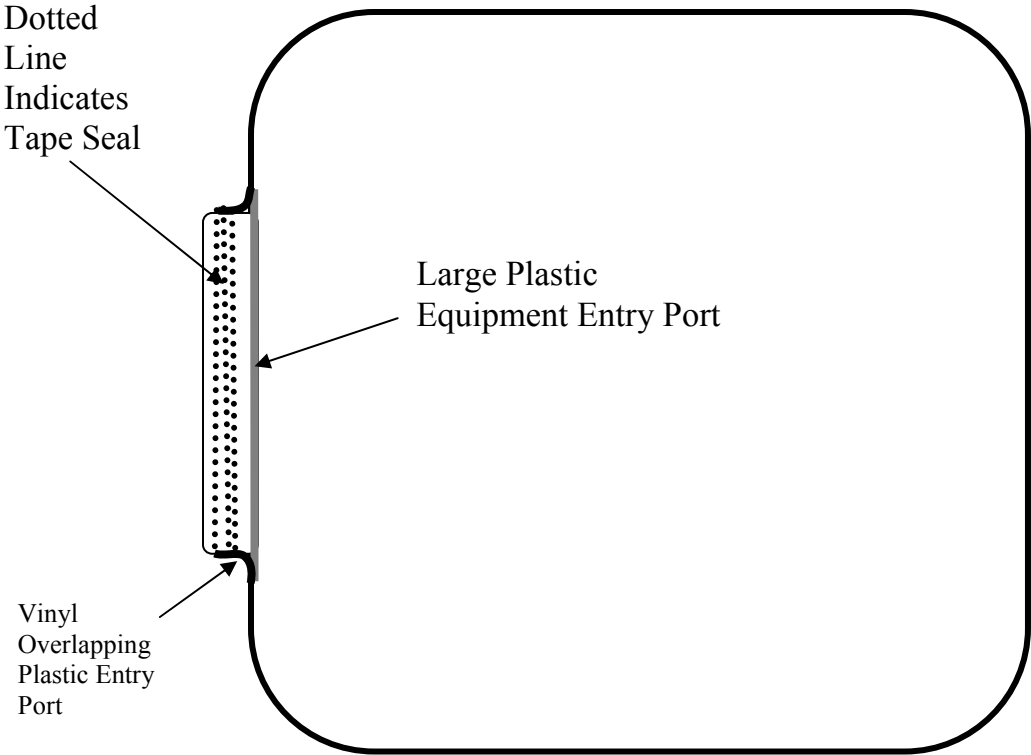

1.3 Glove Box Components

Figure # 3 Basic Glove Box

Font View

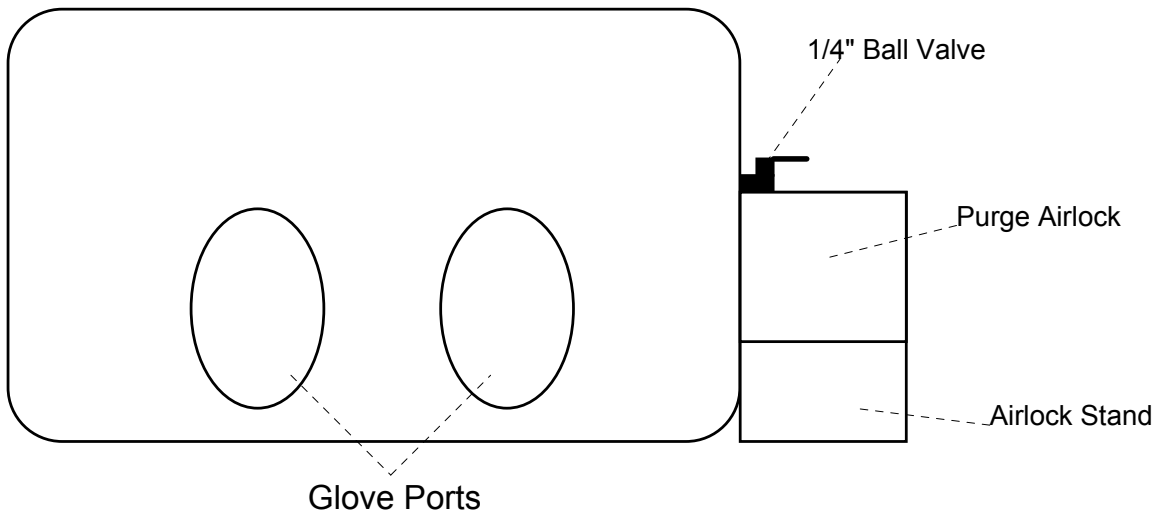

Top View

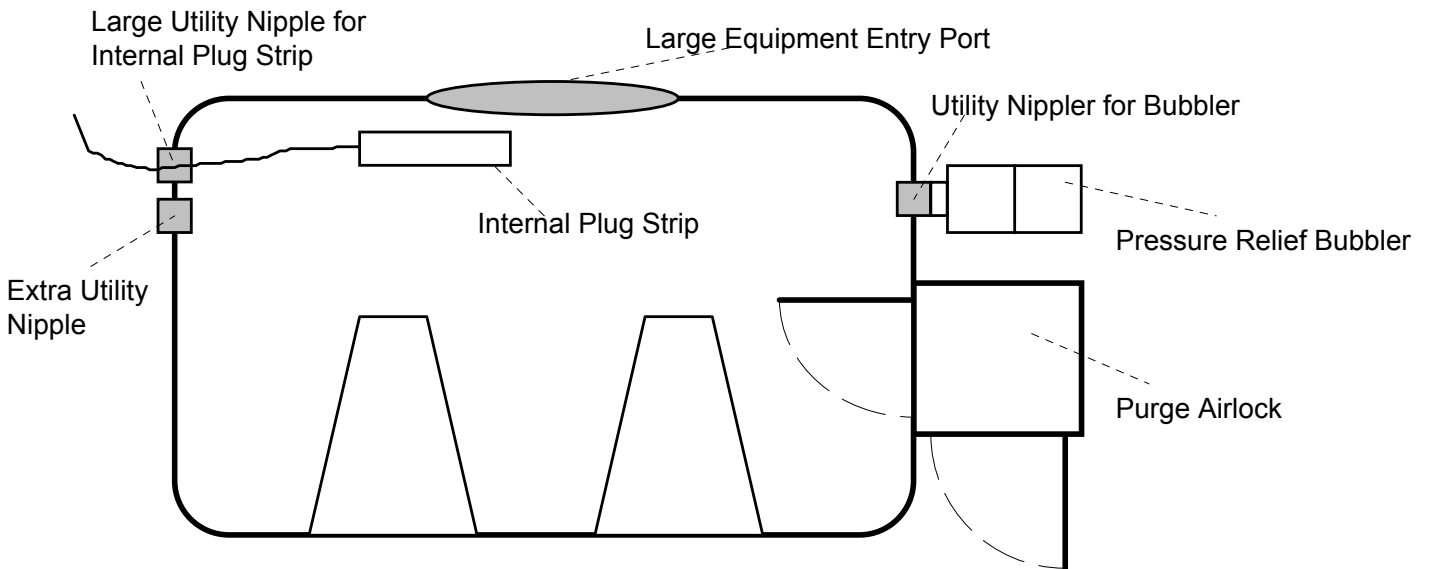

1.3.1 ¼” NPT Ball Valve

This ball valve located on the upper right side of the glove bag (see figure # 3) can be used for purging operations. The ball valve is equipped with a ¼” O.D. quick disconnect female and male fittings for tygon tubing. To install tygon tubing to the fittings, follow the instructions listed below and Figure # 4 (below).

1. Place a female fitting on each end of tubing.
2. Place 2 ty-wraps around the hose barb on the female fittings and pull them as tight as possible.
3. Cut off excise ty-wrap.
4. Insert Female fitting connected to the tubing to the Male fitting on the Glove Box Ball Valve. When fitting is seated correctly, you will hear a “click”.
5. To disconnect the tubing, simply depress the silver tab on the male fitting.

WARNING: Never purge the glove box at a higher rate than 15 psi. (with ¼” OD Tubing) Doing so could over pressurize and damage the glove box.
NOTE: Damage from over pressurizing the glove box will void the warranty.

Figure # 4 Tubing connection to Quick Disconnect Fitting

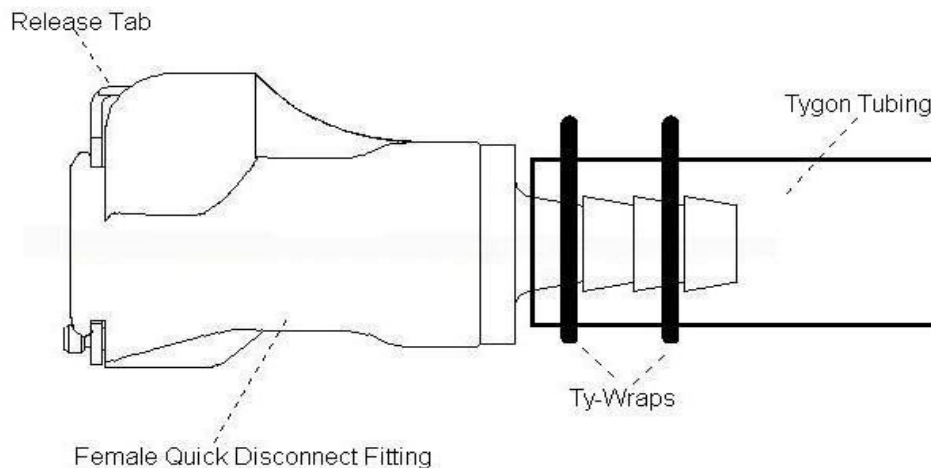

1.3.2 Pressure Relief Mechanism (Bubbler)

The pressure relief bubbler relieves the glove box of large internal pressure changes associated with gas purges. The system automatically allows gas to escape to the room atmosphere when the glove box’s internal pressure rises.

The Bubbler can handle up to 15 psi of gas flow. Larger flow rates may over pressurize and damage the glove box.

How It Works

The Bubbler is filled with mineral oil. The amount is up to the end user but enough to cover up to the inner dividing wall to form the initial barrier. Closer to the bottom edge the lower the internal pressure in the glove box the closer to the top the higher the internal pressure. The higher pressure translates into the difficulty the user will have in entering the gloves.

As the pressure builds, the liquid moves from the first chamber to the second (see figure #5). When the pressure builds to a certain point the mineral oil is pushed below the dividing wall and air is released (bubbled) into the second chamber.

To adjust pressure levels add, more mineral oil through the hole in the top of the second chamber; or, using the ball valve and the supplied tubing, drain some of the oil out of the Bubbler. When draining the oil out, do not drop the mineral oil below the chamber dividing wall (see Figure #5).

NOTE: No more than 473 ml (1 pint) should ever be present inside the relief mechanism. If you are unsure, drain the bubbler completely and measure the amount poured into the Bubbler.

For a sealed atmosphere a ¼” NPT Cap can be screwed into the threaded opening of the hole in the top of the second chamber or the entire Bubbler can be removed from the Utility Nipple and sealed with a 1.5” size rubber stopper.

Figure # 5 Pressure Relief Mechanism/Bubbler

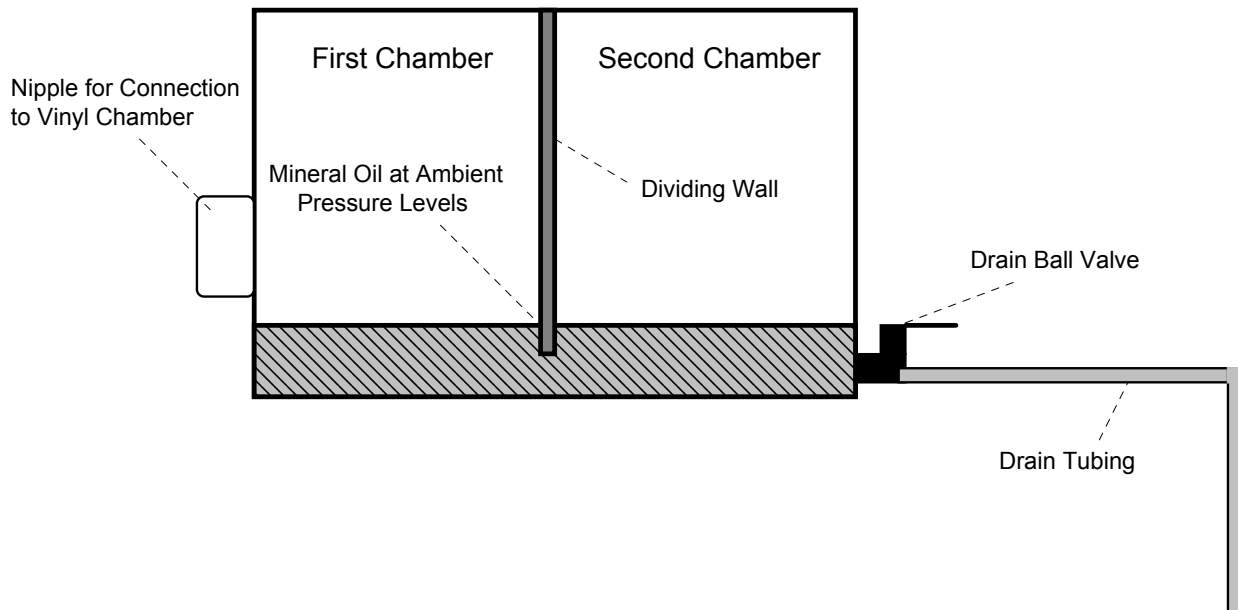

1.3.3 Plug Strip & Utility Nipples

A power supply is sealed into the glove box through the COY Feed Through Adapter. The plug strip is equipped with a circuit breaker and an ON/OFF switch.

The Feed Thru-Adapter is a rubber stopper that has been cut apart to accept the cord of the plug strip and resealed with silicone and placed in the utility nipple. Push the rubber stopper as far in to the utility nipple as possible to ensure an airtight fit.

NOTE: If you adjust the length of the plug strip cord you may want to place a small amount of silicone around the cord and the rubber stopper to ensure the airtight seal

Installing cords into the extra utility nipple

1. Measure the cord diameter being passed through the Chamber Wall.
2. Mark the center of the rubber stopper.
3. Use a drill bit slightly smaller in diameter than the cord diameter and drill a hole in the rubber stopper.

NOTE: The Rubber Stopper will get hot when drilling the hole.

4. Use a sharp Knife to cut the rubber stopper as shown on Figure #6

Figure # 6 Rubber Stopper

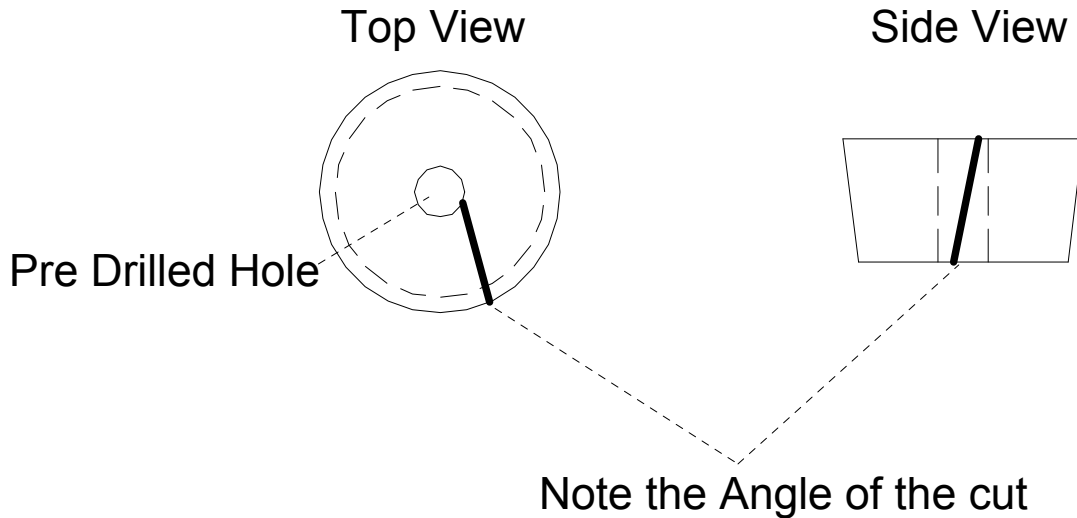

5. “Peel open” the rubber stopper and place a small amount of silicone in the drilled hole.
6. Place the cord into the hole, careful to position the cord to the ideal length inside and outside of the glove bag. Squeeze the rubber stopper over the cord and clean up the excess silicone with alcohol and paper towels.

2.0 CARE AND MAINTENANCE

2.1 CARE OF PVC

2.1.1. PRECAUTIONS

Here are several precautions you can take to prolong the life of your glove bag. Precautions you should carefully follow are:

1. Do not set equipment with sharp edges on the chamber floor. Use rounded and smooth finish work pads to support such items.
2. Always keep small instruments and sharp objects on the work mats. If you don't, they may get lost under the work pad and puncture the PVC.
3. Keep equipment and shelving units within easy reach so you do not stretch the chamber sleeves.
4. Rings and other jewelry (watches should be removed prior to using.

2.1.2. CLEANING THE PVC

Any commercially available cleaner recommended for polyvinyl chloride (PVC) will be sufficient for cleaning dust, dirt and grease off the chamber and restoring its optical clarity. Coy Lab. Products uses "PLASTIC CLEANER MAGIC" (part number 1600-480). It is also available at hardware stores or super markets. You should avoid cleaning the chamber with products containing ketones or other compounds that will damage PVC.

Sanitizing the chamber

With proper care, Isopropyl Alcohol (100%) or a 1%-2% Clorox Bleach solution may also be used. Make sure all excess is wiped off *completely*. Peracetic acid may also be used to sterilize the chamber.

2.1.3. DETECTING LEAKS

1. Using a Gas Leak Detector COY part # 7000-050 (not supplied), soak a rag in alcohol. Place the rag on the inside of the glove bag. The alcohol is necessary as the gas leak detector only picks up hydrocarbons present in the alcohol.
2. With the inside door open, inflate the chamber until the arms become extended. This stretches the vinyl and makes it easier to find small leaks.
3. Turn the Gas Leak Detector on and turn the sensitivity to the highest level and allow it to "warm-up" for 5-10 minutes. After the "warm-up" period, turn the sensitivity down to the lowest point. If the "beeping" slows down, then the Leak Detector is ready.
4. Turn the sensitivity up slightly so that you can audibly hear an increase in the beeping.
5. Now begin to go slowly over the entire glove bag. Pay special attention to all the seals and seams, especially around the sleeves and gloves.

NOTE: The interior of the sleeves and gloves will indicate a slight increase in the beeping. This may or may not be a leak as the gloves are the most porous material on the glove bag, thus the slight increase in the beeping noise. A true leak in this area will have a large increase in the beeping noise. Call your local COY representative or the factory if you are unsure.

6. The gloves can easily be checked for leaks by simply pouring water into them. If water drips into the interior of the glove box then the glove should be replaced.

2.1.4 HOW TO PATCH PUNCTURE AND TEARS

Punctures and tears can be easily patched using the vinyl repair kit found in your chamber care kit. If you have lost it or cannot find it, please contact COY for free Vinyl Repair Kit (part # 7005-020). Before attempting to repair chamber leaks, release the pressure on the chamber by opening the side door or both airlock doors until the gloves sag. If the leak is small, directly apply the liquid vinyl repair to the hole and surrounding area. Let it cure for about an hour and reapply. If the leak is large, cut a patch out of the extra vinyl supplied with the vinyl repair kit. Generously spread the liquid vinyl repair around the hole and apply the patch. You may have to temporarily hold the patch in place while the liquid vinyl repair is curing. In about an hour, apply the liquid vinyl repair to the edges of the patch, sealing the patch and PVC together.

After leaks are repaired, check them with your gas leak detector to verify correct repair. NOTE: SINCE LIQUID VINYL REPAIR CONTAINS HYDROCARBONS, WHICH ACTIVATE THE DETECTOR, IT MUST BE FULLY CURED BEFORE VERIFYING CORRECT REPAIR. The liquid vinyl repair works on the principle of softening the vinyl. When the vinyl is soft, it adheres to itself thus eliminating the leak.

2.2 CARE OF GLOVES

2.2.1. PRECAUTIONS

The gloves are made of neoprene rubber and are susceptible to punctures and tears. Wear cotton gloves when working with sharp objects. Remove jewelry. If a hole is punctured in the glove, it must be replaced.

2.2.2. DETECTING LEAKS

Most of the leaks found in the chamber will occur in the gloves. Leaks can be detected in the gloves by using the gas leak detector or by hanging it with the fingers outstretched and pouring water into it.

2.2.3 REPLACING A DAMAGED GLOVE

Damaged gloves may be replaced without losing the atmosphere using the following instructions and Figure #11.

1. Obtain the extra glove and cuff, supplied with your chamber care kit. COY suggests the use of double sided tape to hold the new glove onto the cuff. A strip of the tape around the wide end of the cuff, and the glove stretched over it will hold the glove in place.

2. On the inside of the chamber remove the tape from the glove (figure #11 A).
3. Pull the glove through to the outside of the chamber (figure B) but do not remove it from the sleeve yet.
4. Carefully fold the sleeve in half and clamp the fold (figure C). The clamp can be created by 2 smooth pieces of wood and 2 clamps.
5. With the clamp in place you may now pull the used glove out of the sleeve and insert the new glove. The vinyl should fit snugly around the middle of the new cuff.
6. Remove the clamp and insert the glove into the interior of the chamber and tape it in place using the Vinyl Yellow Tape from COY. Start the first revolution of tape half on the vinyl sleeve and half on the neoprene glove. Overlap revolutions as you go around the cuff.

Figure #7 Glove Replacement Procedure

